

Project Name	Fixture Type	Catalog #	Quantity
<input type="text"/>	<input type="text"/>	<input type="text"/>	<input type="text"/>



### Design Features / Specifications

**Housing:**

Injection-molded, engineering grade, 5VA flame retardant, high-impact resistant, thermoplastic in gray or black finish. Fully gasketed clear polycarbonate cover.

**Listing & Ratings:**

Meets UL924, NFPA 101 Life Safety Code, NEC, OSHA, Local and State Codes. UL Listed for wet locations (20°C - 40°C). Certification to CEC under Title 20 Regulations available as an option.

**Mounting:**

Universal knockout pattern on back plate for wall mount. Snaps into place making internal electrical connections.

**Illumination:**

Adjustable high performance 3.3W high lumen white LED lamps with smooth metalized reflector and glass lens for optimal light distribution.

**Electrical:**

Dual 120/277 voltage. Charge rate/power "ON" LED indicator light and push-to-test switch for mandated code compliance testing. LVD (low voltage disconnect) prevents battery from deep discharge. Includes 6 volt, maintenance-free, rechargeable sealed lead acid battery. Internal solid-state transfer switch automatically connects the internal battery to LED lamp heads for minimum 90-minute emergency illumination. Fully automatic solid-state, two rate charger initiates battery charging to recharge a discharged battery in 24 hours.

**Warranty:**

Five year warranty on all electronics and housing. Battery pro-rated for two years.

### Wet Location LED Emergency Light

Catalog #	Description
<input type="text"/>	<input type="text"/>

**Complete Units Ordering Information**

Example: WEL

<input type="text" value="WEL"/>	<b>Model:</b>	WEL = Wet Location Emergency Light
<input type="text"/>	<b>Housing Color</b>	(blank) = Grey B = Black
<input type="text" value="WP"/>	<b>WP</b>	Wet Location
<b>Options</b>		1. CEC - Title 20 Compliant 2. USA - Assembled in USA



### Dimensional Information

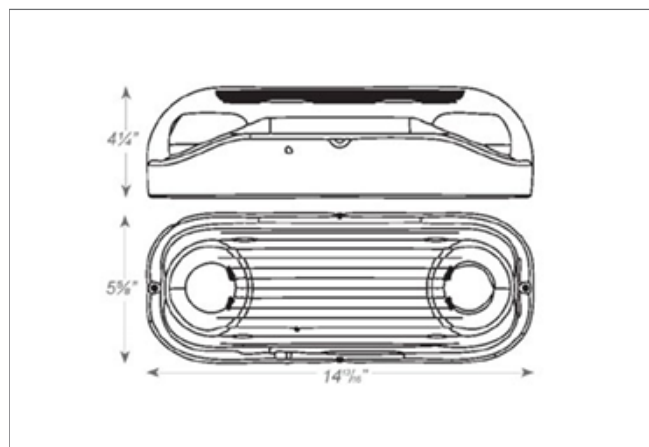

*Note: RENOVA products are constantly being improved; therefore, the information shown is subject to change without notice. Always consult your lighting representative or RENOVA Lighting Systems, Inc. for the latest information.*